



SN388 Dual-Module Operation with Indigenously Designed Interface

Purushottam Siripole
ONGC, Chennai,

Summary

SN388 Telemetry System has an inherent limitation that with a single PAM Module only 1200 channel Data can be acquired at 2 ms Sample Interval. During the Field Season 2006-07, GP-12 of GS - Chennai was assigned the task of acquiring 1296 channels using SN388. To implement this, the SN388 System was to be put into Multi-Module Operation cascading two PAMs. The OEM recommended procedure for implementing this involved procurement of Accessory kit from OEM, M/s. Sercel, France, involving an expenditure of Rs. 6.8 Lakhs. Geophysical Services, Baroda had already acquired this Accessory kit. An intensive study of the Hardware of the Accessory kit established that the necessary Interface can be indigenously implemented. Accordingly, the necessary drawings were generated and the Hardware implemented using In-House resources. The Module was successfully put into operation in GP-12 for cascading two PAM Modules and Seismic Data was acquired deploying 1296 active channels. This resulted in starting the operations in time and also in a cost saving of nearly Rs. 6.8 Lakhs as ONGC Chennai had almost finalized procurement of Accessory kit from OEM for this Multi-Module Operation

Introduction

For implementing the SN388 two-module configuration OEM recommended Interface was already in use at Baroda. This involved the procurement of the Accessory kit, **1A13072480A**, from OEM. The setup using the OEM Accessory kit is shown in Figure 1.

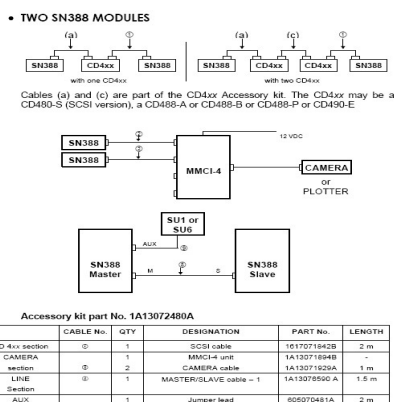

Figure 1: Two Module Connections and Accessory kit

As soon as the requirement of Multi-Module Operation came up in GP-12, GS Chennai a detailed study of the existing setup at Baroda was carried out. This revealed that the Interface could be implemented using only Cables and connectors and without using MMCI-4 unit. The function of MMCI-4 unit is only to simultaneously generate plots of traces from both the Modules. But the requirement of plots could be met by plotting the traces from the Master Module in real time and Slave Module in Playback mode. This led to indigenously designing the Interface using suitable connectors available in-house. An in-house Software developed by Author was already in place for generating Screen Plots, Spectrum and carrying out QC checks. This was done in the Recording Cabin on a Windows-Xp based PC connected to the Ethernet Adaptor Hub for collecting the Data using FTP.

Methodology

The inter-connecting diagram for two-module configuration using the indigenously assembled MASTER/SLAVE Interface cable is as shown in Figure 2 with an additional PC for generating Screen Plots, Spectrum and carrying out QC checks. The



steps of methodology are highlighted for quick understanding.

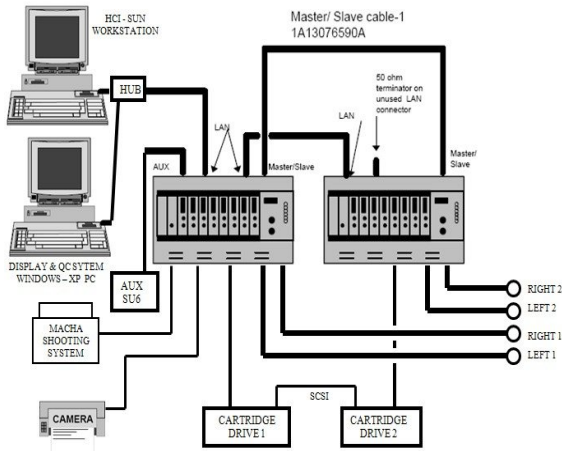

Figure 2: Two Module Connections inside the Cabin

- ❖ A Master/Slave cable is connected between the two PAMs, making one of them Master. The cable's plug identified as "Master" should be connected to the Master module and the plug identified as "Slave" should be connected to the Slave module.
- ❖ The connections of OEM design cable (Part No. 1A13076590A) were checked to make a similar cable with matching connectors.
- ❖ LAN Cable between two modules must be connected with LAN-out of Master Module to LAN-in of Slave Module and termination on LAN-out of Slave Module. Master Module's LAN-in is connected to Ethernet Adapter Hub.
- ❖ Both the modules have to be defined and configured in the Module Configuration Setup of GO-388 window. Identity Card shows two modules after configuration.
- ❖ Data Recorded on two Cartridges using 3490E Drives simultaneously.
- ❖ Camera plots Data Acquired by Master PAM in real time and requires a Playback operation for plotting Data Acquired by both the PAMs.

- ❖ Display & QC System is plugged into the Hub to get the data using FTP. SN388 Data Analysis – Utilities developed in-house, used for Display of Acquired Data, Trace Analysis and Trace Spectrum.

The connectors used for inter-connecting the two modules are 19-pin Bendix type. 15 connections are made from one end to the other. One of the connectors or plug is to be identified as "Master" and the other connector or plug as "Slave".

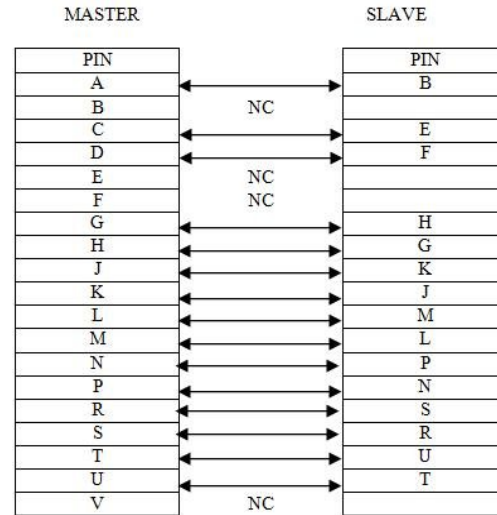

Figure 3: Master / Slave Connections

The OEM design cable bearing Part No. 1A13076590A has the connections between Master and Slave Connectors as shown in Figure 3.

The modules are mounted on their shock mounts with the connector sides facing each other so that the inter-connecting becomes easier. The CRT monitor was replaced with slim 19-inch LCD monitor from the available spares of 408UL System. The Display & QC System was mounted adjacent to the LCD monitor. The plotter's position is changed to leave enough space on the Tabletop for two Observers to comfortably work. The initial problems due to non-availability of enough Ground units and Cables were taken care of by timely intervention of SAOM and provided by borrowing from other Regions. The Test & Maintenance System, TMS was shifted from REL and installed in the base camp for faster turn-around of Ground Electronic units after repairs.

The Geometry of Acquisition with 12 lines of 108 channels each with 300m line interval has posed few problems in the beginning. A suitable definition of Line Configuration has been decided upon and Data Acquired by both the Modules has been recorded



seamlessly. The Data integrity has been tested on FPU and at RCC.

The Data Acquisition was successfully carried out by GP-12, GS - Chennai with the above arrangement in KG Basin during the Field Season 2006-07.

Conclusions

The indigenous efforts of undertaking the Dual-Module interfacing resulted in :

- Starting early operation as the Accessory kit from OEM was not required.
- Saving cost to the tune of Rs. 6.8 Lakhs as the material requirement of implementing indigenous Interface was met from in-house resources.
- The same can be implemented for similar operations with SN388 in any Region without any additional expenditure as the active channel requirement in Geophysical Data Acquisition is much above 1200 which is the limitation of single PAM module of SN388.

References

SN388 INSTALLATION MANUAL – Chapter8.
MULTI-MODULE INSTALLATION