

Addressing Reservoir Heterogeneity of Miocene Basal Sand and its Hydrocarbon potential in Akholjuni Field, Cambay Basin, India

Editha Mary*, A.K. Jena, Neetesh Singh, V.L.N Avadhani & P.P. Deo
CEWELL, ONGC, Makarpura Road, Vadodara-390009
DHAN_EDITHAMARY@ongc.co.in

Keywords

Facies, MBS, fluvio-deltaic, laminated

Summary

Akholjuni, an emerging field of Cambay basin, lies north of Mahisagar cross-fault which separates the tectonic blocks of Cambay-Tarapur and Broach. At the base of Babaguru formation, the most prolific producer in the area, Miocene Basal Sand (MBS) is situated. With an average sand thickness of around 20m, the production history of wells studied for MBS has been quite intriguing when viewed in respect of entrapment and facies where structurally low wells have produced good amount of hydrocarbon and structurally higher wells have produced water even though these are envisaged to be part of a single corridor. In light of these challenges an effort has been made to understand the correlativity of MBS, sand dispersal pattern, facies variation and entrapment condition. Core study, NMR data and log correlation along with seismic was used as input in the study.

A detailed interpretation on the 3D seismic volume was carried out to understand the structural disposition. Time and depth structure map close to MBS top were prepared which shows anticlinal highs with lows in between. Entire Akholjuni structure is found to be cut by major Dharwarean trend faults and equally affecting cross-faults resulting in compartmentalization as different fault blocks. These fault blocks along with producing wells appear to be grouped in the form of two major structural clusters. The north-western and western wells are located in structurally highest and rising part causing them to be prolific producers. Tracing the area south of these wells it is observed that wells at similar structural elevation have produced water as well as oil of which the southernmost well, considered to be structurally lowest, is producing oil. This study brings out the problem of reservoir heterogeneity in terms of structure playing pivotal role in hydrocarbon entrapment. Considering these parameters prospective areas for exploration/exploitation identified are NW, South and SE area of the Field.

Introduction

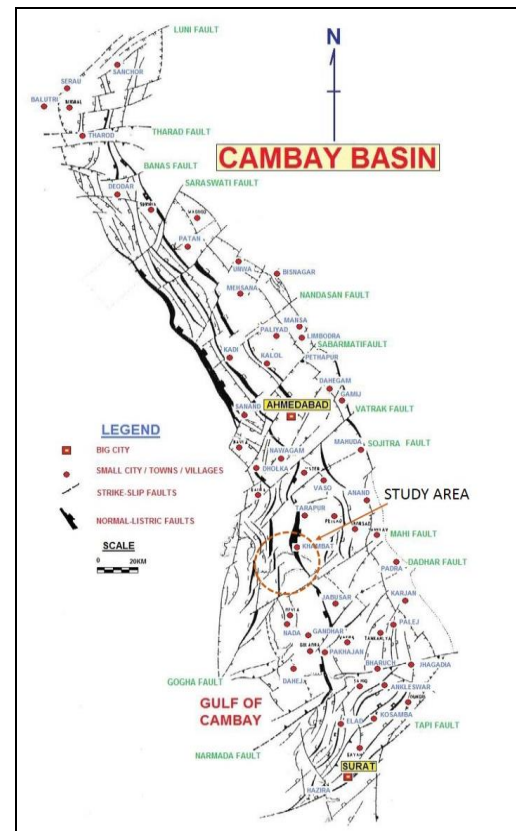

Fig-1: Tectonic map of Cambay basin (Kundu et al 1996) showing Study area

To understand the depositional set up earlier G&G models for Akholjuni field and MBS sand in particular have been taken into consideration. Deposition of Miocene basal Sand (MBS) is envisaged to be distributary channel sands often reworked by tidal energy (K.K. Das, R.R. Saundriyal). Deccan-Tap Formation of Late Cretaceous age acts as the technical basement for Tertiary sediments of Cambay basin overlain by

Addressing Reservoir Heterogeneity in Akholjuni Field

Paleocene to Lower Eocene syn-rift deposit sediments of Olpad Formation which in turn is unconformably overlain by Cambay Shale (Lower to Middle Eocene) that has been divided into Older and Younger Cambay Shale with an unconformity in between named as Y-marker (Pandey et al., 1993). Cambay shale is overlain by regressive Kalol delta systems of Middle Eocene age which hosts the EP-III and EP-IV pays and has produced from nearby Cambay field. Major transgression during Late Eocene-Early Oligocene was responsible for the deposition of the Tarapur Shale over Kalol Formation. Tarapur shales are overlain by Miocene to Recent sediments of Babaguru, Kand, Jhagadia Formations and Gujarat Alluvium. During Miocene continued subsidence facilitated the formation of depo-centers that have acted as loci of deposition of enormous thickness of sediments of Babaguru and later formations.

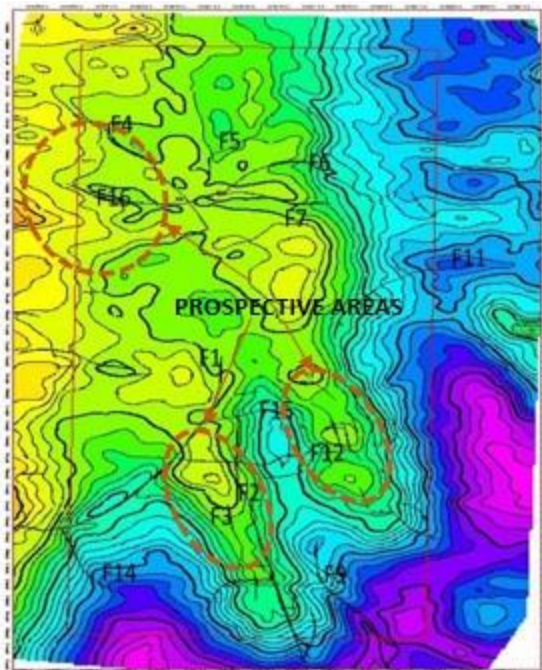

Fig-2: Depth structure map of Akholjuni field at MBS Top level

The study area lies in south western rising flank of Tarapur and north western rising flank of Tankari-Broach depressions. Tarapur and Tankari-Broach depressions are connected by the synclinal area located between Akholjuni/Cambay and Kathana highs, running east of the study area. As a result the

eastern side of the structure has lower elevation. The study area is characterized by presence of two NNW-SSE trending anticlinal highs developed over intra-basinal basement blocks. At Olpad and EP-IV levels the anticlines are doubly plunging (NNW-SSE) but as we move to MBS level the anticlines become gentler and towards North-West gradually fade away into western rising flank of Cambay basin. The anticlinal highs are dissected by NNW-SSE trending longitudinal and E-W to NE-SW trending transverse fault systems. The two major longitudinal faults trending N-S are associated with Half-graben setup wherein the Limbs of shoulders are locales of accumulation of sediments forming Structural culminations. Though the area can be divided into various blocks, these fault blocks along with producing wells were grouped in the form of two major structural clusters. The north-western and western high-lying-rising blocks taken together forms a group and the other is the eastern low elevation group. Hydrocarbon pools appear to be associated with fault bound anticlinal highs and are affected by their respective shale or water-contact.

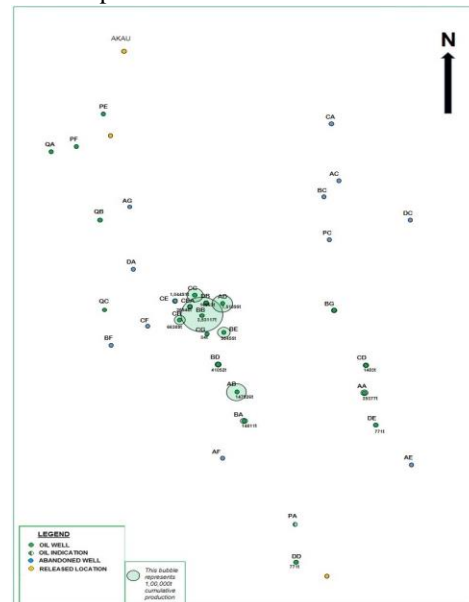

Fig 3: Bubble map showing cumulative production of wells from MBS pay as on 1-2-2018

The main anomaly in the study area associated with MBS pay is that bubble map (Fig-3) for this pay depicts very low producing wells located close to good producers. As seen in the main block, well CG

Addressing Reservoir Heterogeneity in Akholjuni Field

has produced only 4T while its surrounding wells have BE, BB and CB have produced 98455T, 353117T and 66389 T respectively. This behavior needs a rational explanation

Theory and methodology

The core studies carried out aided by log signatures as well as from various reports by RGL, Vadodara, suggests MBS pay to be an Arenaceous unit comprising thick sandstone at base and alternation of sandstone and shale litho-facies at top. On the basis of sedimentary structures and log signature MBS unit can be divided into three sub-units with varying characteristics. The basal sub-unit comprises of fine to coarse grained sandstone and exhibits a typical coarsening up trend. The middle subunit comprises of fine to medium grained and moderately sorted sandstones with shale layers. The topmost subunit is a fining upward sequence. Sandstones in general are fine grained and exhibit moderate to good sorting. Sand bodies comprising of MBS unit are considered to be of fluvio-deltaic origin. These sands are often reworked or influenced by tidal energy.



Fig-4: Envisaged sand dispersal pattern of the area

Sweetness attribute (ratio of reflection strength and frequency) and variance were used to deduce channel, if any. Time slice at 1284ms shows meandering of channels in northern side of the study area and suggests sandy deposit in this area (Figure: 4) and surrounding areas are inferred to be shaly areas because of low values of sweetness.

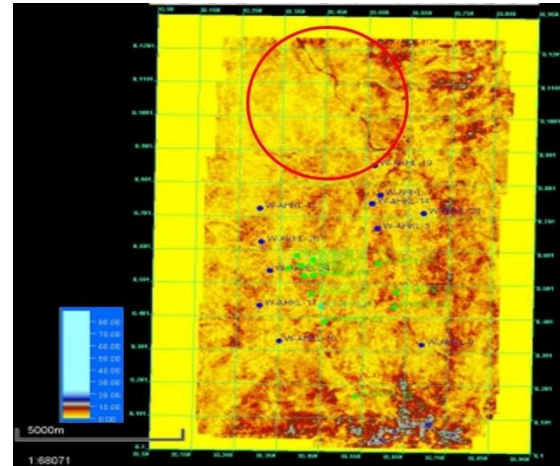

Fig-5: Fig: sweetness timeslice showing path of channel

To further understand the sand dispersal pattern log correlation aided by fence diagram was studied.

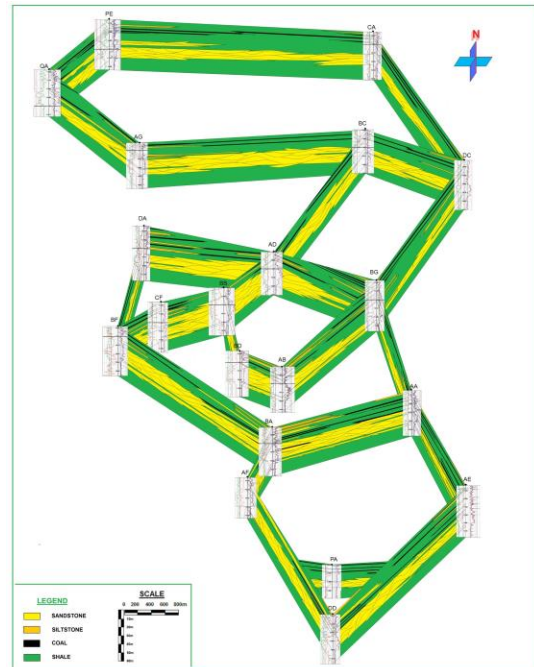

Fig-6: Fence diagram showing dispersal pattern of MBS sand

Addressing Reservoir Heterogeneity in Akholjuni Field

Accordingly, wells towards the South-east lying close to Tarapur low appear to have lesser thickness while wells lying in the central region seem to have the highest sand thicknesses. This high sand thickness probably corresponds to channel axis. Fence diagram also showed sand on eastern part to be sparse. Around well **AD** and **BB** in the central region thickness appears to be maximum. On moving east the sand thickness decreases considerably around well **BG**. All along wells **BG**, **DC** and **CA** thickness is quit less with respect to rest of the field. These locations may be coinciding with the channel margin. Pack thickness in the western part of the field is good but increase in shale thickness is also observed.

In the log correlation profiles studied, good development of sand is observed along the entire profile for western wells suggesting better sand development with respect to other parts of the study area. As the western area is also structurally higher as well as rising, it poses an ideal condition for entrapment in terms of structurisation.

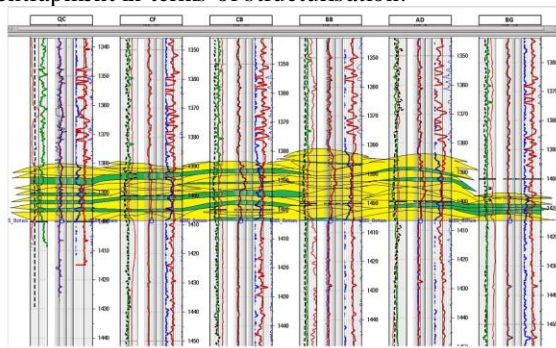

Fig-7: E-W correlation profile, Akholjuni field

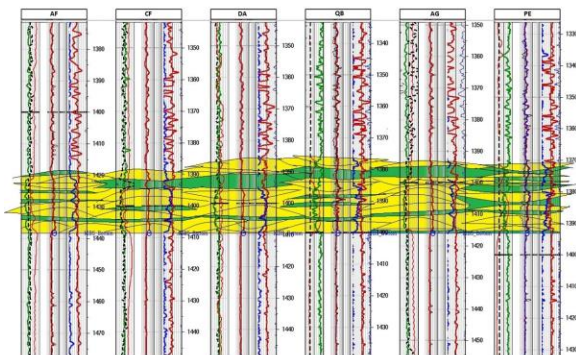

Fig 8: S-N correlation profile including western and north-western block wells

Log correlation and petro-physical evaluation brings in different contacts for the fault bound blocks. On the northeastern region from wells **CA** to **PC**, oil-

water contact at -1391 msl is observed. After well **BG** no oil-water contact is seen, rather oil-shale contact is observed. These two different contacts exist within a single anticlinal corridor due to cross faulting which resulted in compartmentalizing the contacts. In the western block oil-shale contact at -1389m msl is observed which is different from the SE culmination where oil-shale contact was observed at -1430m msl at well **AA**. **Presence of multiple types and depths of hydrocarbon contacts** overlain by the sand dispersal pattern answers for some of the production pattern observed in the area. The SE area, though structurally lowest has produced hydrocarbon owing to the low Oil shale contact of -1430 msl while further north wells appear to be in continuation but have produced water as both the nature and elevation of contact changes. Instead of being Oil-Shale contact (OSC) the contact is observed to be oil-water contact (OWC) lying at -1391 msl for which many wells at higher elevation have turned water producer. This OSC of -1391 is observed in the main block also and as due to structurisation MBS is relatively somewhat higher than in the north-eastern part, the area hosts many producer wells from MBS. On moving further west again a change in contact is observed from OSC to OWC at an elevation of -1389 msl. As this area is structurally highest as well as rising it presents a good probability for producer wells as far as structure is considered. Few good producing wells are present in this area.

Porosity in MBS Unit varies in the range of 15 to 30 % average being 23%, while connate water saturation varies in the range of 41 to 55%, average being 46%. Initial oil-water contact has been found at 1402 meter as encountered in the first producing well **AB** in January-2000 of the block. Initial reservoir pressure in the block of wells **AB** and **AD** was 145 Kg/cm² at datum depth of 1400 meter. It reached to a level of 127.8 Kg/cm² in November-2012 as per available data points. The marginal pressure drop in reservoir pressure against cumulative oil production of 0.857 MMT in November-2012 in the block signifies strong support of aquifer. This is further substantiated by rapid movement of oil-water contact from 1404 meter in January-2000 to 1391 meter in August-2011 as encountered at well **CEA**.

NMR and Capillary pressure studies were carried out in two wells **AF** and **DD**. Two distinct reservoir

Addressing Reservoir Heterogeneity in Akholjuni Field

facies were observed in these wells which appeared as having similar facies on logs. The results of XRD studies also presented similar mineralogical constituents in both wells. Though Porosity was of the same order in both wells, irreducible water saturation, flow characteristics and permeability varied significantly. The T2 distribution spectrum differed in both the wells suggesting variation of pore size. NMR studies also showed that both the wells have different free fluid volume. The free fluid porosity is in order of 17 p.u. in **AF** whereas it is 6p.u. in **DD**. Low free fluid porosity, low permeability and high irreducible water saturation, suggests presence of smaller grain size in **DD** with respect to **AF** and this small grain size may be responsible for decrease in resistivity & permeability. **DD** is hydrocarbon producer but its flowing potential appears to be poor due to small grain size as compared to **AF**, which is water-bearing. Additionally, the permeability values also vary greatly for plugs from same core but different depths. This may be the consequence of the three type of sub facies into which MBS is divided, all of which retain differing flow character.



Fig-9: laminated sequence forming part of MBS from well DD

From the Soxhlation studies in the core from MBS of well DD (Fig-10), it can be observed that hydrocarbon was recovered from entire MBS section with varying proportions. However, the lower sequence-seq I, which is more massive and has better sandy characteristic, initially flowed oil for few days then started producing water. The upper sequence, seq II in Fig-10 is laminated and has produced oil on self. In the north-western region wells with low

resistivity pays have produced hydrocarbon. To better characterize these low resistivity pays cores in good number and logs like RT Scanner/ 3DeX, Image logs and CMR are essentially required.

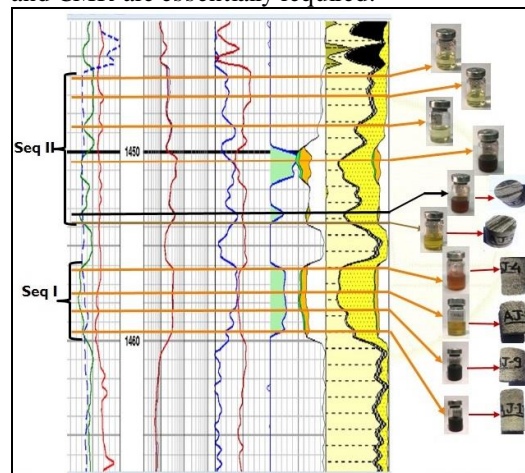

Fig-10: soxhlation study extract for well DD in MBS

Furthermore, XRD studies carried out in well **DD** reveal the sample to contain an average Quartz content of 86.5%, Siderite (up to 22.28% on one of the samples), along with Chamosite & Chlorites (~5-12%). Ilmenite (~3%), Muscovite (~2%) as well as traces of Magnesite, Hematite and Pyrite. So the combined effect of fine-grained nature, laminated sequences of shale with sand/siltstone as well as the presence of ferruginous minerals may aid in suppression of resistivity in MBS.

Conclusion:

- The time structure map close to MBS top shows anticlinal highs with lows in between. The major lows are in the south and eastern part. Most wells have been drilled in these anticlinal highs. The longitudinal faults and the cross faults enclose the anticlinal highs.
- Subtle features are clear in variance time slices. The attribute time slices shows channels at shallower depth and in northern side. Presence of sand is confirmed with the drilling of recent well **DF** in the northwestern side.
- The structure map shows rising highs and intermediate lows in the western side of PML boundary. These highs are not mapped fully in



Addressing Reservoir Heterogeneity in Akholjuni Field

the present two way time structural map due to paucity of seismic data.

- Miocene Basal sand (MBS) of Akholjuni Field consists of Clay-supported massive sand, Massive sand and sand/shale thin laminations.
- The cross faulting has created different blocks in the study area which caused different OWC/OSC within the blocks.
- OSC/OWC for NW part, OSC is at -1389m MSL; for Main Block OWC is at -1391m MSL; for the SE block OSC is at -1430m MSL.
- From core studies and log correlation profiles the depositional regime of MBS looks to be tidal channels/bars with tidal/mud-flats. The sand unit looks to be a stacked unit of tidal bars/channels and inter distributary tidal/mud flats.
- Laminated sequence with shale and sand/siltstone laminations aided by presence of ferruginous minerals may be the reason of low resistivity in producing wells.
- To better characterize these low resistivity pays, cores in good number and logs like RT Scanner/ 3DeX, Image logs and CMR are essentially required.
- Prospective areas identified under this study were NW, South and SE area of the Field which is in agreement with the results of recent wells drilled.

References

K.K. Das, R.R. Saundriyal. Lithofacies, Microfacies and depositional Environment of the MBS unit of Akholjuni field Cambay-tarapur block. RGL ONGC.

Pandey, J Singh, N.P., Krishna, B.R., Sharma, D.D., Parikh, A.K. and Nath, S.S, 1993, Lithostratigraphy of Indian petroliferous basins, Cambay basin Vol I Unpublished sedimentological and conventional core reports by RGL, Vadodara, ONGC

Jena A.K. and Jain R, 2018, Integrated Study of MBS pay-sand Akholjuni field.(ONGC Unpublished Report)

Kundu, J., Wani, M.R. and Thakur, R. K. (1993) Structural styles in South Cambay Rift Basin and its

control on post rift deltaic sedimentation: Proc. of the 2nd Seminar on Petroliferous Basins of India, eds. S.K. Biswas et al., Indian Petroleum Pub., Dehradun, Vol. 2, P. 79-96

Acknowledgement

The authors express their sincere gratitude to Shri R.K. Srivastav Director (Exploration), ONGC for his kind permission to publish this paper. The support by lab group of CEWELL was instrumental. The authors also acknowledge valuable support and essential discussions provided by learned colleagues during the course of this study.